

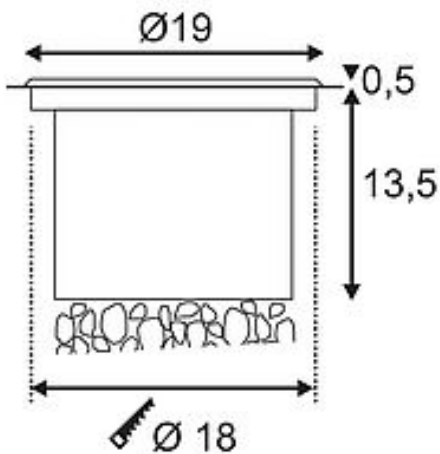

ADJUST 190

outdoor inground fitting, QR111, IP67, round, stainless steel 304, max. 50W

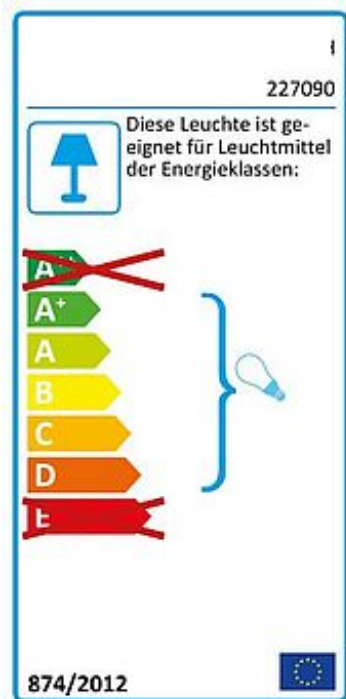

Article number 227090

Feed-in capability No

Lampholder / Socket G53

Number of light sources 1

Lamp included No

Installation diameter 18 cm

Installation depth 14 cm

Tilt range 20 Degree

Rotation range 90 Degree

Depth 13.5 cm

Diameter 19 cm

Net weight 2.3 kg

Gross weight 2.506 kg

Voltage 12V AC

Max. wattage 50 Watt

Protection class I

Energy efficiency class A+

Way of mounting Recessed mounted / Inground

Lamp QR111

Form round

Light distribution type 1 direct

Walkable, low-voltage recessed ground luminaire with round stainless steel cover and partially frosted glass. Rated IP67, it is suitable for outdoor use. To ensure accurate illumination, the lamp is adjustable. The electrical connection is made directly to 230V mains supply via the incorporated transformer. For simplified mounting, an installation housing is included. This luminaire is compatible with bulbs of the energy classes: D - A+

Notes
